

KOMATSU®

PC3000 Super Shovel

OPERATING WEIGHT
250–258 ton **551,500–569,000 lb**

SHOVEL CAPACITY
15 m³ **19.5 yd³ SAE 2:1 heaped**

BACKHOE CAPACITY
15 m³ **19.5 yd³ SAE 1:1 heaped**

PC
3000

SUPER SHOVEL



Photo may include optional equipment.

WALK AROUND

Komatsu Technology and Expertise

Machines innovatively developed for high production and environmental responsibility.

- Quality management ISO 9001 certified
- Environmental management ISO 14001 certified
- High consistent quality through continuous investment in personnel, design and manufacturing systems and processes

Reliability and Durability

Designed for lower operating costs

- Robust structural design developed from field experience and finite element analysis
- Big diameter rollers, idlers and sprockets
- Large surface area and extensive precision hardening reduce wear
- Hardened track link pin bores

Productivity

Designed for more tons per hour

- Powerful digging forces
- Ease of bucket filling
- Proven attachment design
- All cylinders mounted under the shovel attachment for additional protection
- Buckets and Wear Packages to suit all material densities and ground conditions

Easy Maintenance

Simple, common-sense design gives quick easy access to all major components

- Generous access to all major service points from machinery house floor level
- Enclosed, internally lit machinery house with firewall separating engine from pump area
- Automatic central lubrication
- ETM electronic monitoring system providing real time information about the operating status of the machine
- Ground-level access to hydraulically powered swing down service arm with Wiggins connection

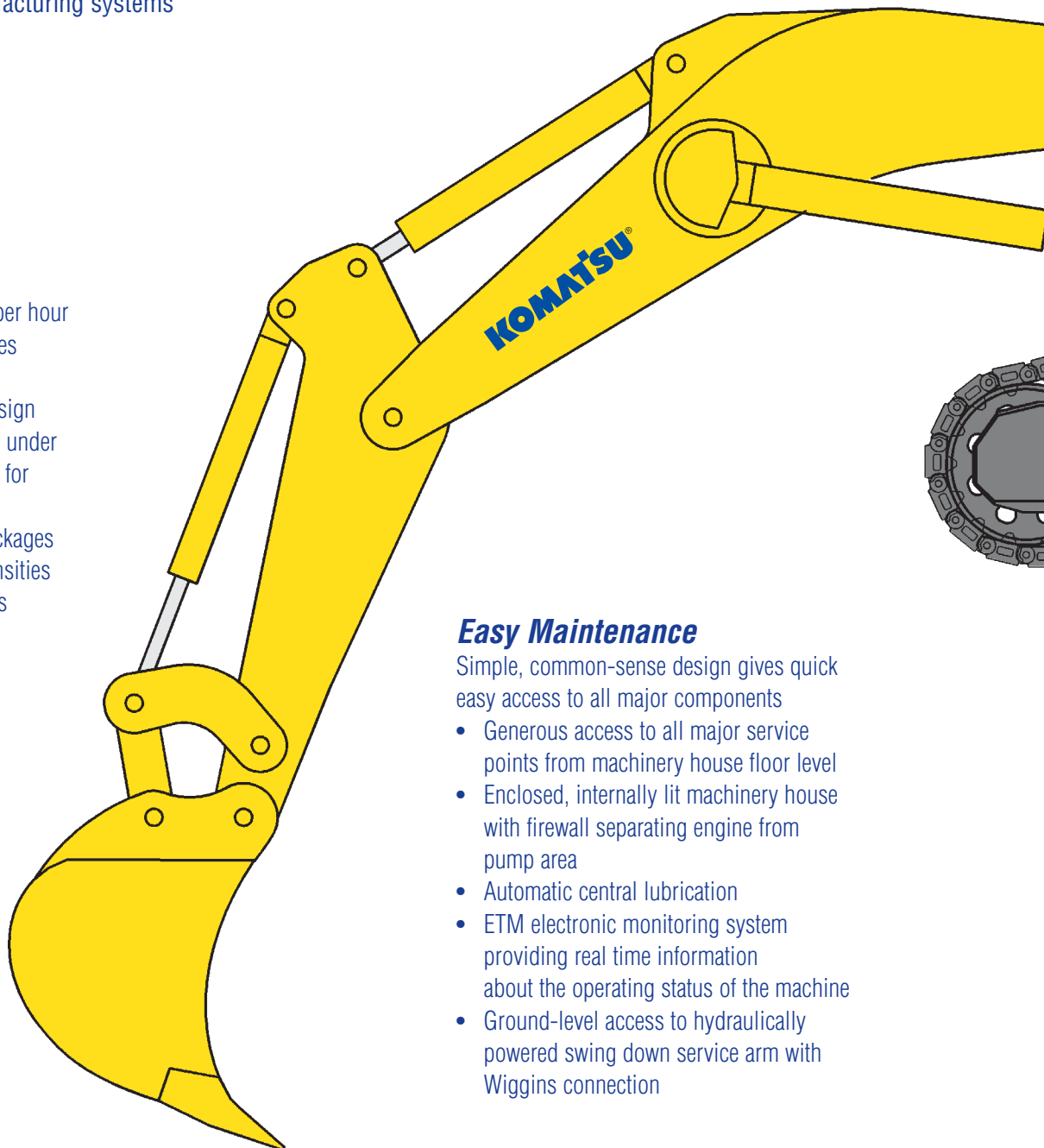

**MATCHED FOR
85–165 U.S. ton TRUCKS**

**SHOVEL AND BACKHOE
BUCKET CAPACITY**
15 m³ 19.5 yd³

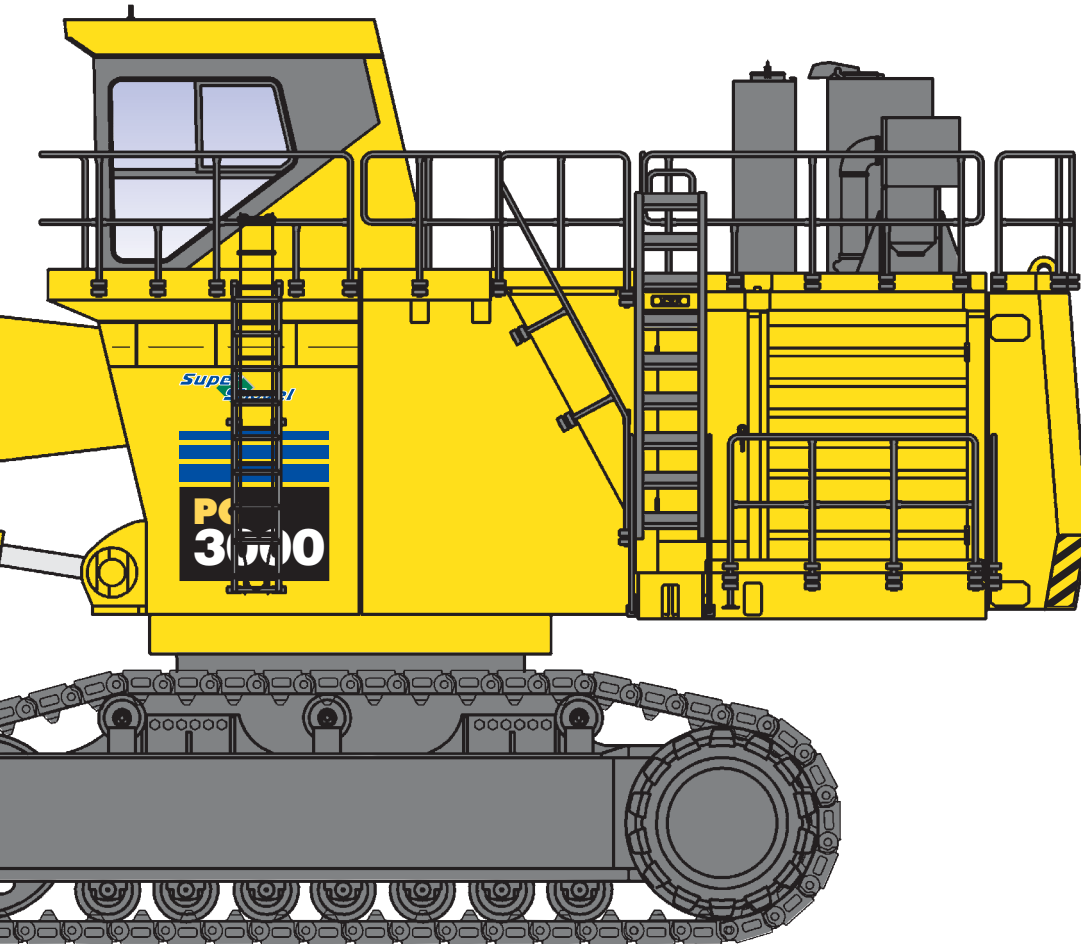

Photo may include optional equipment.

Large Comfortable Cab

Gives full shift comfort

- Komatsu low noise cab on multiple viscous mounts for reduced noise and vibration
- Large volume cab with deep front window
- Comprehensive climate control with pressurised filtered air ventilation and air conditioning
- High specification multi-adjustable air suspension seat
- Well elevated operator position giving good all round view

Advanced Hydraulics

Extended reliability and control

- Electronic pump management
- Comprehensive monitored filtration
- Simple open circuit hydraulic system with high efficiency swing out oil coolers

Powerful Diesel Engine

Single Komatsu SSA12V159 engine

- Rated 940 kW **1260 HP**, at 1800 rpm
- Electronic engine management
- Low engine emission levels meet EPA regulations
- Optional time saving oil management system; Sentinel Engine Oil Management, Engine Reserve Oil Supply and Eliminator Oil Filter systems

SPECIFICATIONS



DIESEL DRIVE

Model Komatsu SSA12V159
 Type 4-cycle, water-cooled, direct injection
 Aspiration Turbocharged and aftercooled
 Number of cylinders 12
 Rated power 940 kW **1260 HP** @ 1800 rpm
 (SAE 1995/J1349)
 Governor All-speed, electronic

*Optional engine oil management system:

The integrated engine oil and filter system combining the oil stabilising systems, Reserve and Sentinel, with the Eliminator self cleaning oil filter extends, with oil analysis, the oil change interval to 4000 hours.



ELECTRICS

System 24 V
 Batteries (series/parallel) 4 x 12 V
 Alternator 150 A
 Standard working lights 4 Xenon lights
 Auxiliary lights 2 lights
 Standard service lights 8 lights



HYDRAULICS

The power train consists of one main drive. Diesel engine or electric motor can be supplied. One gearbox drives three identical main pumps which draw hydraulic oil from an unpressurized hydraulic tank. Open circuit hydraulics provide maximum cooling and filtering efficiency.

Main hydraulic pumps 3x910 ltr/min **3x240 U.S. gal**
 Relief valve setting 310 bar **4,495 psi**
 Swing flow rate 800 ltr/min **211 U.S. gal**
 High pressure in line filters 200 microns
 one per pump located at the valve blocks

Full flow return line filters 3 x 10 microns and leakage line filter 3 microns all with monitored by pass filters 200 microns. at head of tank

The three-circuit Hydropilot system features electronic engine and pump management to optimise hydraulic power for smooth hydraulic action, fast response, simple system layout and a reduced number of components. Filtration is at the oil intake to pumps, valve blocks, heat exchangers and oil tank.



DRIVES AND BRAKES

Travel control 2 foot pedals
 Gradeability Up to 70%
 Travel speed (maximum) 2.4 km/h **1.5 mph**
 Service brake Hydraulic brake
 Parking brake Wet, multiple-disc



SWING SYSTEM

Hydraulic motors and drives 1
 Swing brake, service Hydraulic brake
 Swing brake, parking Wet, multiple-disc
 Swing ring teeth External
 Swing speed (maximum) 4.6 rpm



ELECTRIC DRIVE

Type Squirrel-cage induction motor
 Power output 900 kW
 Voltage 6600 V*
 Amperage (approximate) 105 A
 Frequency (standard) 50 Hz @ 1500 rpm
 Optional frequency 60 Hz @ 1800 rpm

*Other voltages available on request



UNDERCARRIAGE

Undercarriage consists of one center carbody and two track frames, each side attached by 38 high torque bolts.

Center frame H-type
 Track frame Steel box-section



CRAWLER ASSEMBLY

Track adjustment Automatic hydraulic type
 Number of shoes 46 each side
 Number of top rollers 3 each side
 Number of bottom rollers 7 each side



COOLING SYSTEM

The high capacity engine radiator is cooled by a mechanically driven fan for superior cooling efficiency and requires little maintenance. The hydraulic system includes two large swing-out vertical air-to-oil hydraulic coolers with temperature-regulated hydraulically driven fan.



AUTOMATIC CENTRALISED LUBRICATION

Two hydraulically powered Lincoln single line automatic lubrication systems are provided as standard, complete with time and volume variable controls. Activity and malfunction events are linked to the ETM. The central lube grease system is supplied from a refillable 200 litre **53 gal.** barrel. A second, identical system supplies open gear lubricant to the swing ring teeth through a lube pinion. Replenishment of the barrels is through the service arm.



SERVICE CAPACITIES

Hydraulic oil tank 2900 ltr **765 U.S. gal**
 Hydraulic system 4400 ltr **1,160 U.S. gal**
 Fuel 4500 ltr **1,190 U.S. gal**
 Engine coolant 360 ltr **95 U.S. gal**
 Engine oil 190 ltr **50 U.S. gal**



CAB

The large welded steel cab incorporating the ISO 3449 FOPS structure is vibration isolated with 15 viscous combination pads and sound insulated to 73 dB(A). It is equipped with automatic climate control and is pressurised. The operator's seat is air suspended, electrically heated and has a lap seat belt.

There is a trainer's seat.

Low effort joy stick controls are hydraulic with foot controls for front shovel clam, crawler and swing brake.

Full instrumentation and ETM are provided. AM/FM radio is fitted. Two windshield wash wipers are synchronised and have two speed and intermittent operation.

2 heated rear view mirrors are externally fitted. External metal sun blinds. There is a left hand sliding window. All windows are tinted parsol green.



VEHICLE MONITORING SYSTEM

The ETM electronic health monitoring system, mounted in the operator's console, continuously monitors the performance of the engine, gearbox, autolube and hydraulic systems. Fault messages are immediately available to the operator via a digital display and in the event of critical malfunctions the engine is also shut down.

The digital storage provides failure summary and analysis, which can be down loaded by laptop computer. This data will assist in predicting or reducing downtime.



OPERATING WEIGHTS (APPROXIMATE)

PC 3000 Backhoe:

Operating weight including 8600 mm 28'3" boom, 4000 mm 13'1" stick, 15 m³ 19.5 yd³ backhoe bucket, operator, lubricant, coolant, full fuel tank and standard equipment.

Shoe Width	Operating Weight	Ground Pressure
800 mm 31"	253 t 557,900 lb	23.7 N/cm ² 34.4 psi
1000 mm 39"	258 t 569,000 lb	19.4 N/cm ² 28.1 psi

PC3000 Front Shovel:

Operating weight including 6000 mm 19'8" boom, 4300 mm 14'1" stick, 15 m³ 19.5 yd³ shovel bucket, operator, lubricant, coolant, full fuel tank and standard equipment.

Shoe Width	Operating Weight	Ground Pressure
800 mm 31"	250 t 551,500 lb	23.4 N/cm ² 33.9 psi
1000 mm 39"	255 t 562,300 lb	19.1 N/cm ² 27.7 psi

Explanation

- 1 Cab
- 2 Power Train
- 3 Hydraulic Cooler
- 4 Hydraulic Reservoir
- 5 Valve Blocks
- 6 Swing Motor
- 7 Fuel Tank
- 8 Counterweight
- 9 Autolube Systems

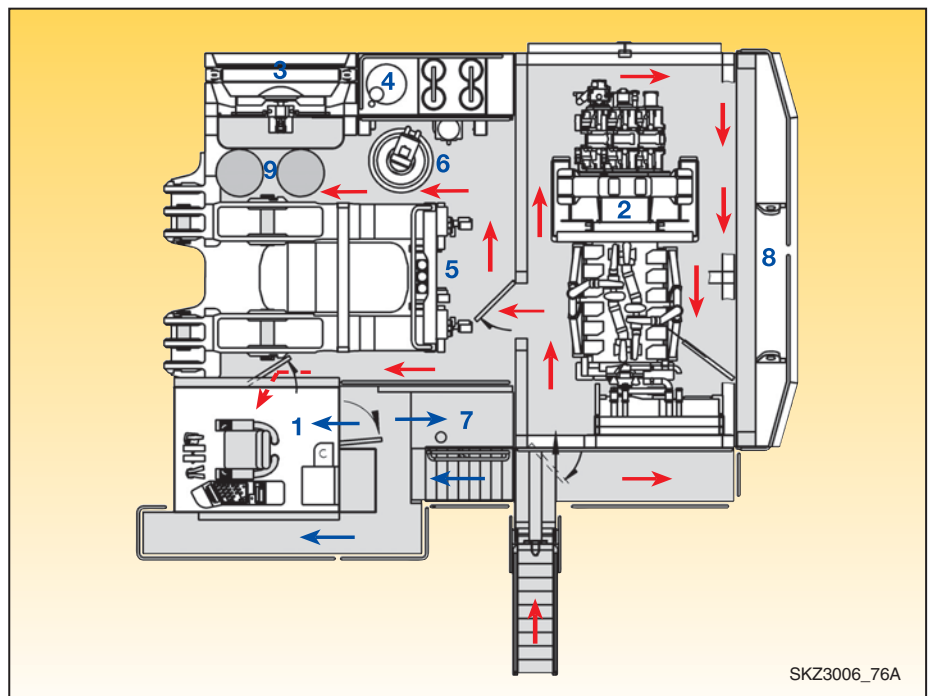

SKZ3006_76A

PRODUCTIVITY FEATURES

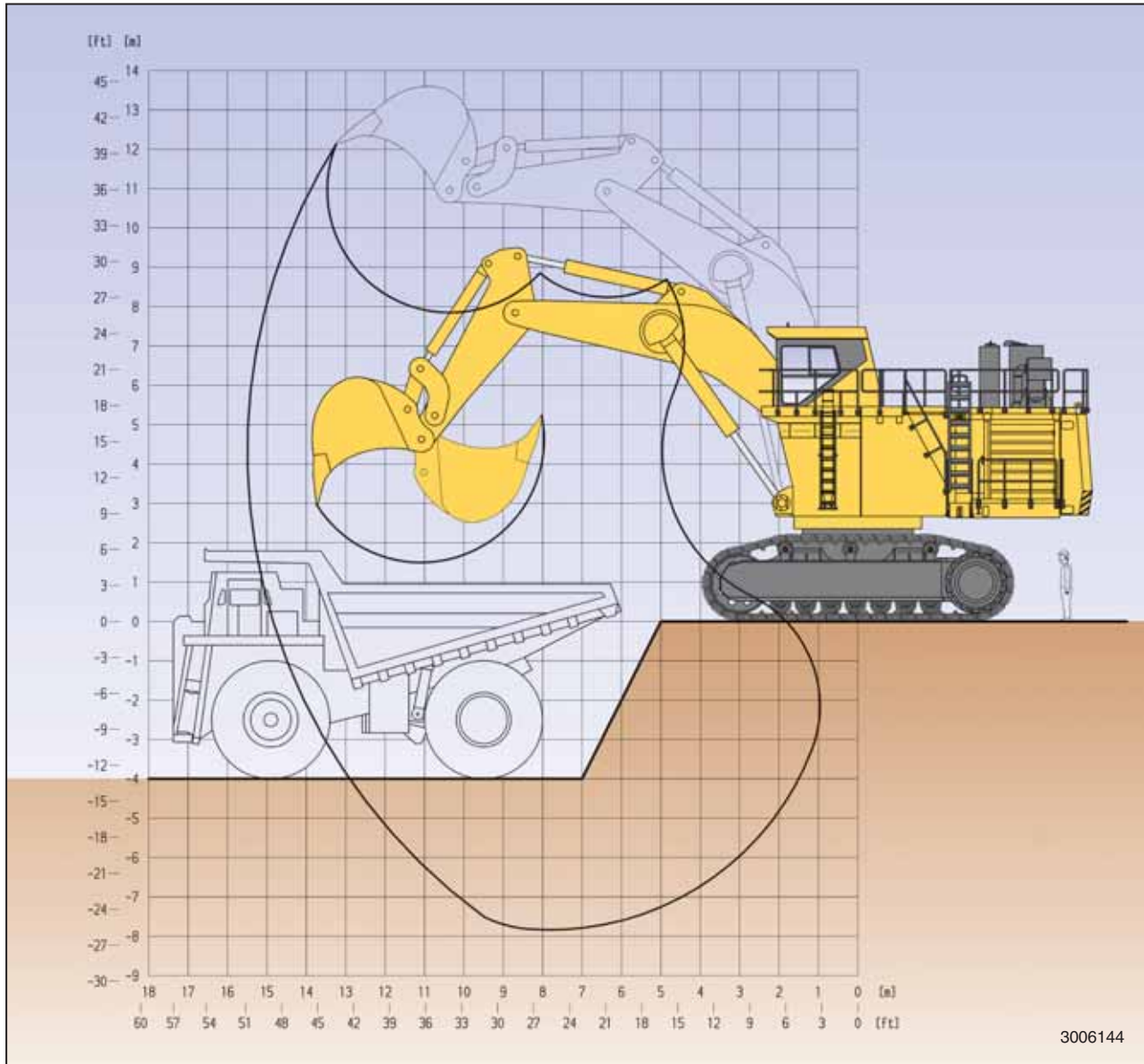

 **DIGGING FORCES**

Break-out force	850 kN	191,000 lb
Tear-out force	800 kN	179,800 lb

Maximum reach at ground level	14850 mm	48'9"
Maximum digging depth	7800 mm	25'7"

 **BACKHOE BUCKET, STICK AND BOOM COMBINATION**

Bucket Capacity	Width	Weight	Teeth	Boom Length 8600 mm 28'3"
SAE Heaped 1 : 1		including Wear package-2		Stick Length 4000 mm 13'1"
15 m ³ 19.5 yd ³	3400 mm 11'2"	15.6 t 34,400 lb	5	Material weight to 1.8 t/m ³ 3000 lb/yd ³

Alternative buckets/wear packages are available

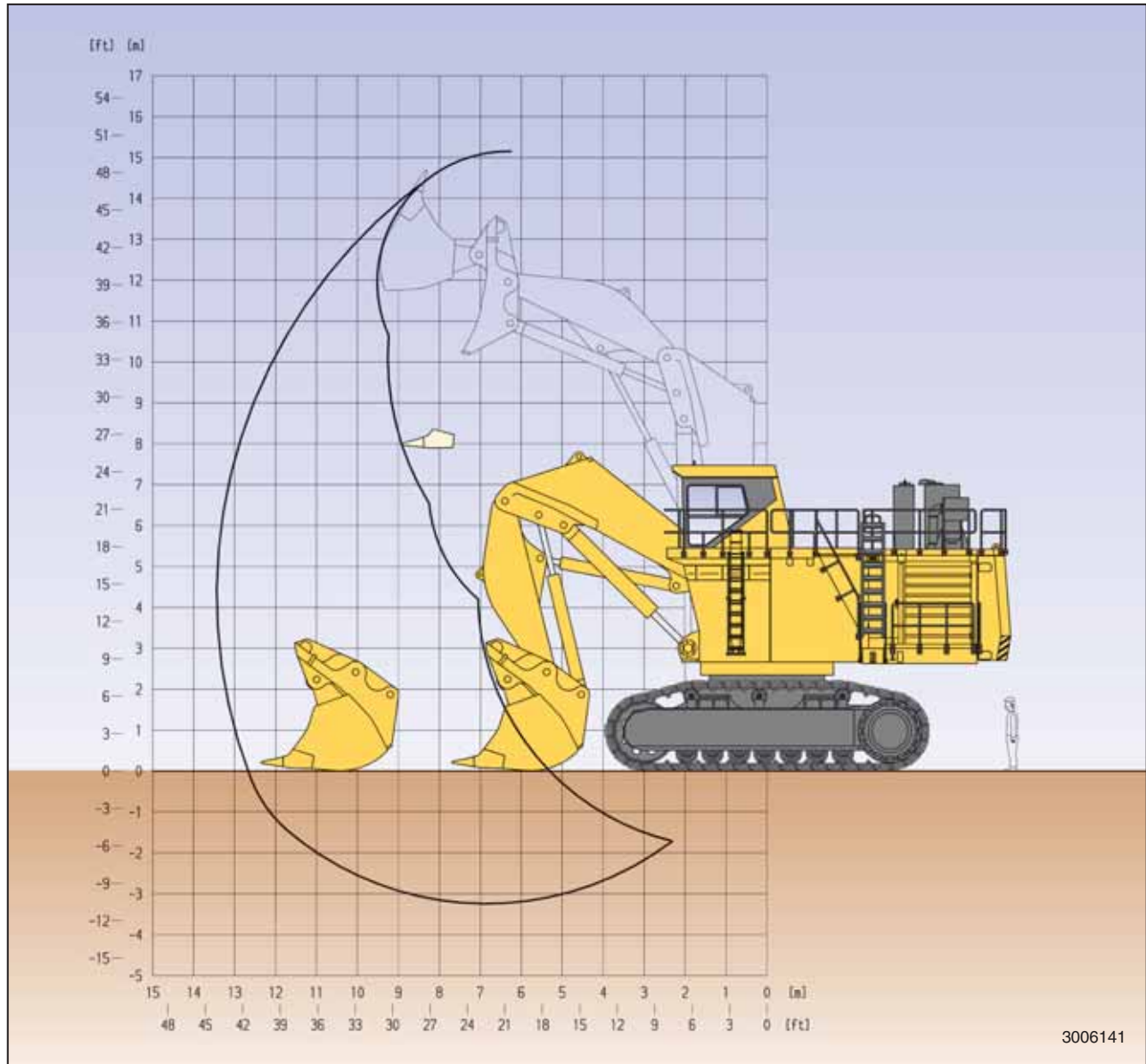

3006141



DIGGING FORCES

Break-out force	1000 kN	225,000 lb
Crowd force	1100 kN	247,500 lb

Level crowd at ground level	.4700 mm	15'5"
Maximum dumping height	.10200 mm	33'6"



SHOVEL BUCKET, STICK AND BOOM COMBINATION

Bucket Capacity		Width	Weight	Teeth	Boom Length
SAE/CECE					6000 mm
Heaped 2 : 1	Heaped 1 : 1	3790 mm	including Wear package-3	6	Stick Length
15 m ³	17.4 m ³				4300 mm
19.5 yd³	22.7 yd³	12'5"	23.1 t		Material weight to 1.8 t/m ³
			51,000 lb		3000 lb/yd³

Alternative buckets/wear packages are available



STANDARD EQUIPMENT

Hydraulic Mining Shovel with Diesel Drive will comprise:

- **FRONT SHOVEL ATTACHMENT**
6.0 m **19'8"** boom and 4.3 m **14'1"** stick complete with cylinders. 15 m³ **19.5 yd³** (SAE 2:1) shovel bucket with mechanical teeth and lip system.

OR

- **BACKHOE ATTACHMENT**
8.6 m **28'3"** boom and 4.0 m **13'1"** stick with 15 m³ **19.5 yd³** (SAE 1:1) bucket with mechanical teeth and lip system.
- **CRAWLER UNDERCARRIAGE**
Heavy-duty shovel type undercarriage consisting of a center carbody and 2 heavy box-type track frames, each having 7 bottom rollers, 3 top rollers, and 800 mm **31"** cast steel track shoes. Hydraulic track adjustment and parking brake provided.

- **SUPERSTRUCTURE**
The main frame mounted over an externally toothed swing circle carries the main drive module, including Komatsu SSA12V159 diesel engine, oil and fuel reservoirs, counterweight, operator's cab and base.
- **LIGHTING**
4 Xenon high performance working lights. 8 service lights throughout platform. 2 auxiliary lights.
- **OPERATOR'S CAB**
Fully enclosed steel cab which incorporates the ISO 3449 standard FOPS structure and CARRIER SÜTRAK air-conditioning unit. Mounted on viscous pads. GRAMMER full suspension operator's seat with lap-belt. An auxiliary seat. Full selection of controls, switches, and ETM (Electronic Text Monitoring). Joy stick and pedal-operated controls are hydraulic.

Windshield wash wipers with two speed and intermittent operation. (reservoir 7 ltr **1.8 gal**). AM-FM radio. External metal sun blinds. Left hand sliding windows. All windows tinted parsol green.

- **LUBRICATION**
LINCOLN central lubrication for basic machine, attachment, and bucket. 200 ltr **53 gal** refillable barrel.
LINCOLN automatic pinion lubrication system for swing circle teeth with 200 ltr **53 gal** refillable barrel.
Service point (diesel version only as Standard) on hydraulic arm carrying WIGGINS fluid receiving connectors for filling of fuel, engine oil and coolant, hydraulic oil, and the evacuation of coolant, and hydraulic and engine oils.
- **ACCESSORIES**
Acoustic travel alarm
Hydraulically actuated ground access ladder
Electric air horn



OPTIONAL EQUIPMENT

- 1000 mm **39"** track shoes
- Extra or alternative, lighting
- Fire suppression system
- Low temperature package
- Engine oil management system

AQUADIGGER pontoon mounted marine excavator (further details on request from factory)
Electric drive version on request



DIMENSIONS

BASIC MACHINE WITH COUNTERWEIGHT

A	800mm	31"	H	2710mm	8'11"
B	1000mm	39"	I	2570mm	8'5"
C _A	5600mm	18'5"	J	6685mm	21'11"
C _B	5800mm	19'0"	K	7485mm	24'7"
D	2160mm	7'1"	L	3010mm	9'11"
E	3000mm	9'10"	M	2980mm	9'9"
F	6000mm	19'8"	N	6780mm	22'3"
G	7910mm	26'0"	O	5950mm	19'6"
			O _R	6480mm	21'3"

Ground Clearance: 920mm **3'0"**

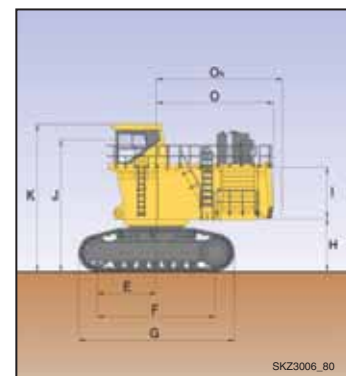
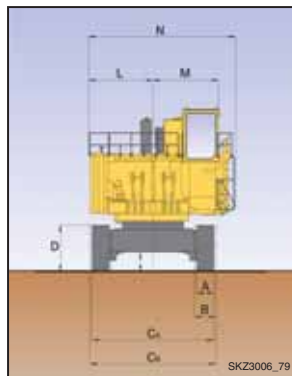

AESS673-01

©2007 Komatsu America Corp. Printed in USA

K01(750C) CCI

01/07 (EV-1)

KOMATSU®